



DIRECTIONS

Components of the System

The Gallery Lighting System consists of four main components. (See Illustration 1)

- **Transformer (1)** to convert wall voltage (120 volts) to 12 volts, plus cable for connection to the wall-mounted track.
- **Junction Box (2)** to connect the 12-volt cabling from the transformer to the track-mounted blue cable, which powers the light wands.
- **Blue Track Cable (3)** to carry the 12-volt current along the length of the track to each light wand. Double-sided adhesive tape secures the cable to the track.
- **Light Wands and LED Lamps (4)** ready to attach at any point along the track.

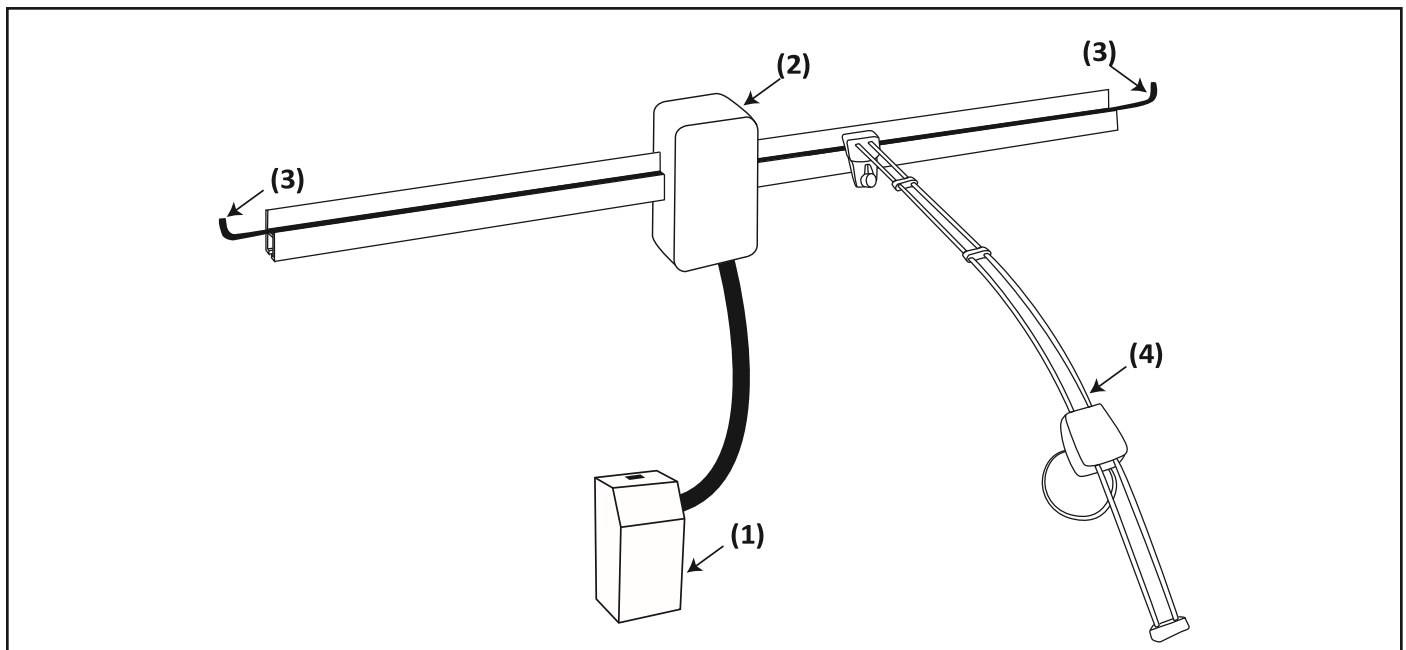

Illustration 1

Planning Your Lighting System

1. Positioning Transformer and Junction Box

Low voltage power (12 volt) is very safe but cannot travel long distances, so the location of power connections to your hanging system should be planned carefully. Power can travel up to 50 feet (15.2 meters) in either direction from the Junction Box. The Junction Box can be located at one end of the wall-mounted track, or, for maximum installation length of up to 100 feet (30.5 meters), be placed in the middle of the track (See Illustration 2).

Each 300 VA transformer can run a maximum of 24 x 7-watt LED lamps if the Junction Box is mounted centrally, with a maximum of 12 on each side. If the Junction Box is mounted at one end of the track, it can power a maximum of 12 7-watt LED lamps. **NOTE: BULBS DRAWING OVER 20 WATTS SHOULD NOT BE USED WITH GALLERY SYSTEM LIGHTING EQUIPMENT.**

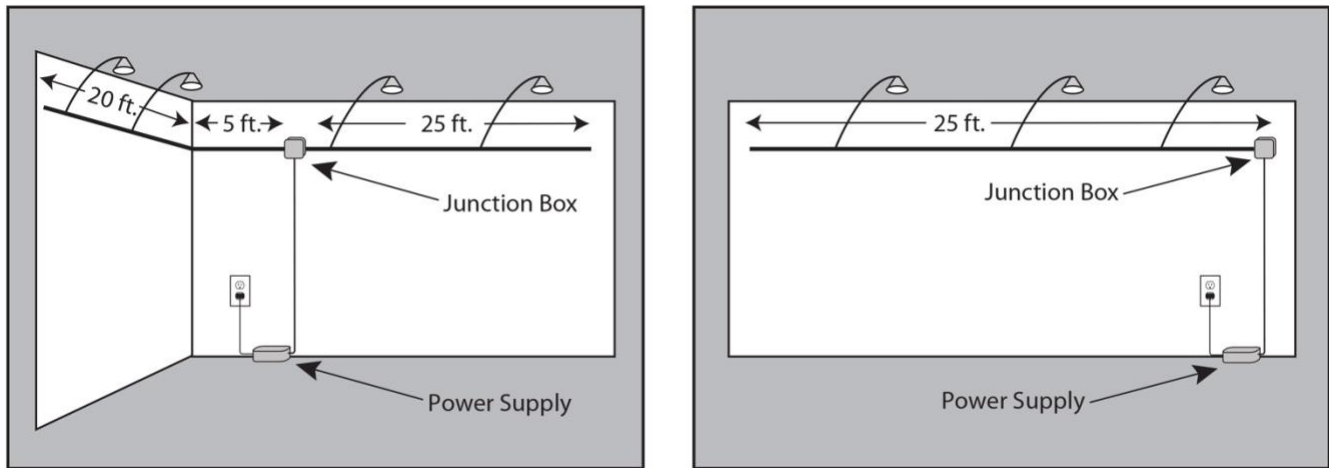

Illustration 2

2. Height of Track

Recommended height is about 8 feet, and tracks should not be mounted higher than 9 feet. This positions the lamps close to the art and maintains a more-effective angle for the lighting.

3. Need help planning your system?

For larger installations you may need help. Send us a floor plan of the area and indicate where the track and lights are to go. Also show the location and height of available power points. We can then plan the job and work out a quotation.

Contact us at: www.galleriesystem.com or by phone at 800 - 460 - 8703

Installation of Your Lighting System

1. Position of Transformer

The transformer should be mounted on the wall where it can get ample ventilation during operation. It can also be placed above the ceiling or behind a wall with the 12-volt power cable installed in the wall cavity where applicable. Either way, it must be well ventilated. If the power lead has to run down the wall plastic conduit (not included) may be used to cover the cable. The transformer is supplied with a 9-foot, 12-volt output lead; this is the recommended maximum distance from the transformer to the track. Larger installations may need two or more transformers and be divided into sections – please contact us for further information.

2. Cutting the Track/Double-sided Tape

Next cut the lengths of track to fit your installation. Allow 2-¾ inches of clear space for each **Junction Box**.

Before screwing the track to the wall affix the double-sided Adhesive Tape to the track. (See Illustration 3.) The track surface should be wiped with rubbing (isopropyl) alcohol before fixing the tape.

Important – Do not remove the strip covering the adhesive at this stage, as it will attract dust and grit while you are affixing the track to the wall.

3. Affixing the Track & Junction Box

Now screw the track to the wall. Screws should be 16 to 18 inches apart. Allow at least 1 inch of clearance between the top of the track and ceiling for attaching the wands.

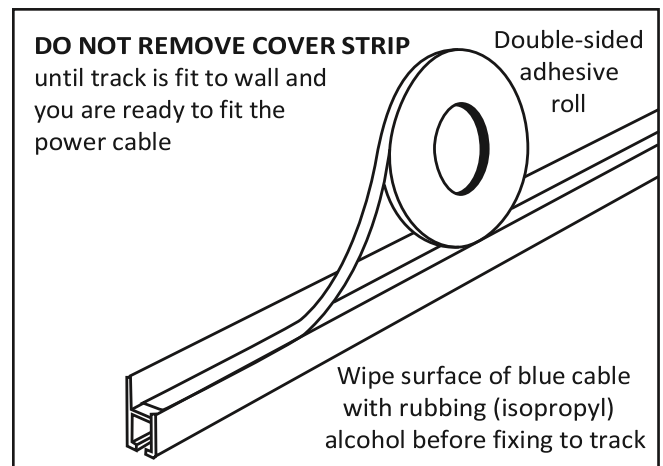

Illustration 3

After removing the lid, fix the **Junction Box** to the wall using the adhesive pad fitted to the box for smooth surfaces. On rough surfaces you may need to screw the box into position. The cable from the transformer must enter the box through either the top round hole or the bottom round hole in the cover of the box (normally the bottom is the end with the circuit breaker buttons showing).

Before fixing the box in place, it is important to position it so that the cable slots in the side of the cover are aligned with the track surface which carries the cable. You can fix the box either way up according to whether your transformer is above or below the track, but normally it would be positioned so that the circuit breaker buttons show at the bottom. If you position the

box so that the circuit breaker buttons show at the top, you will need to leave additional space between the track and the ceiling to allow for the box and access to the circuit breaker buttons.

4. Cutting and Connecting the 12-volt Cable from the Transformer

The 12-volt cable from the transformer (brown cable) can enter the **Junction Box** from either end. In general, the bottom of the box will be the end with the circuit breaker buttons showing, so the end of the box that the cable enters will depend on whether you are mounting the transformer above or below the track.

If you are leading the 12-volt transformer cable into the end of the **Junction Box** that has the circuit breaker buttons showing (normally the bottom of the box – so the transformer would be positioned below the track), then measure cable length to the outer cover of the box and allow an added 4 ¾ inches for the cable which goes inside the box.

If you are leading the 12-volt transformer cable into the end of the **Junction Box** that does NOT have the circuit breaker buttons showing (normally the top of the box – so the transformer would be positioned above the track), then measure cable length to the outer cover of the box and allow an added 1¼ inches for the cable which goes inside the box.

Carefully strip away ½ inch of the insulation from the end of each lead of the 12-volt transformer cable. Connect these to the two OUTSIDE connections at the END of the connection block in the **Junction Box** using a flat blade screwdriver. (See Illustration 4 to ensure that you have made the connections correctly.)

Space inside the **Junction Box** is tight. Therefore, if you are leading the 12-volt transformer wires into the end of the box that has the circuit breaker buttons showing, it will be best to position the wires as shown in Illustration 4 so that they will not interfere with fitting the lid.

Connect the other end of the 12-volt transformer cable to the terminal block inside the transformer.

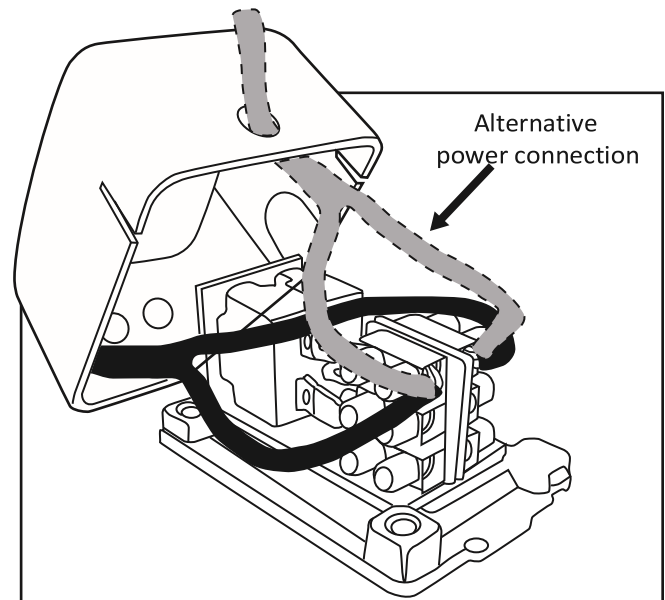
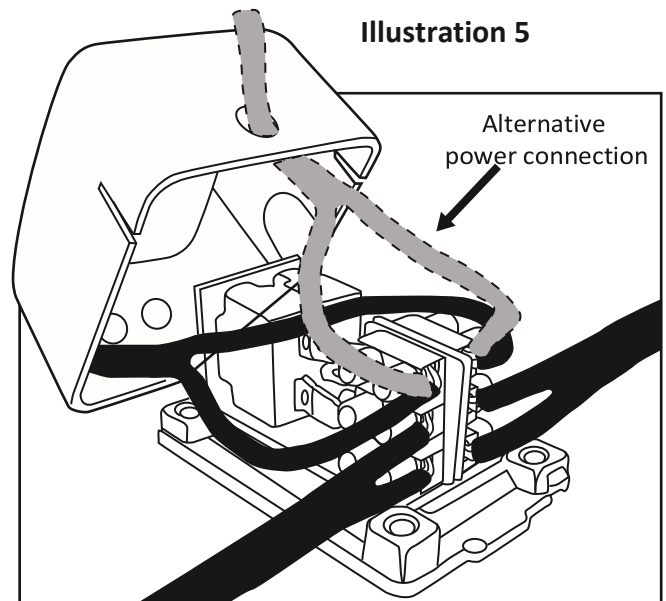

Illustration 4

To do this, first remove the transformer cover and push out one of the knockout hole covers. Fix the cord grip loosely in the knockout hole and feed the transformer cable through it. Strip away ½ inch of the insulation from the ends of each lead of the transformer cable and connect them to the transformer terminal block. Tighten the cord grip onto the transformer cable.



5. Cutting and Connecting the Blue Track Cable

For the blue track cable, measure from the **Junction Box** to one end of one track section and add a couple of inches to allow for connections. If you are installing lights on both sides of the box, repeat the process for the other end of the track. Carefully strip away ½ inch of the insulation from the ends of each lead on one of the blue track cables. Connect these to the two **INSIDE** connections on one side of the connection block in the Junction Box using a flat blade screwdriver. Do the same for the other blue track cable if you are installing lights on both sides. (See Illustration 5 to ensure that you have made the connections correctly.)

6. Fitting the Blue Track Cable to the Track

Pack the cables around the base of the **Junction Box** as shown in Illustration 5. Fit the lid in place so that a blue track cable exits through the slots on each side.

If the blue power cable has attracted dust or grease, first wipe its surface with rubbing (isopropyl) alcohol. (It will dry quickly.) Then peel the paper cover strip from the double-sided adhesive tape which you have already fitted into the track and carefully lay the blue cable in position on the adhesive tape, making sure it lies straight in the track. Trim the cable ends.

The blue power cable will bend easily around corners. On inside corners bend the cable right into the corner so it will allow fitting of the corner cover.

7. Corner Covers (Optional)

These cover the blue cable where it goes around corners. The two types are to fit inside and outside corners. (See Illustrations 6a and 6b.) Also, straight covers hide the blue cable where there's a gap in the track. They are available in two finishes to match track. Use some of the double-sided tape, attached at each end, so they won't move.

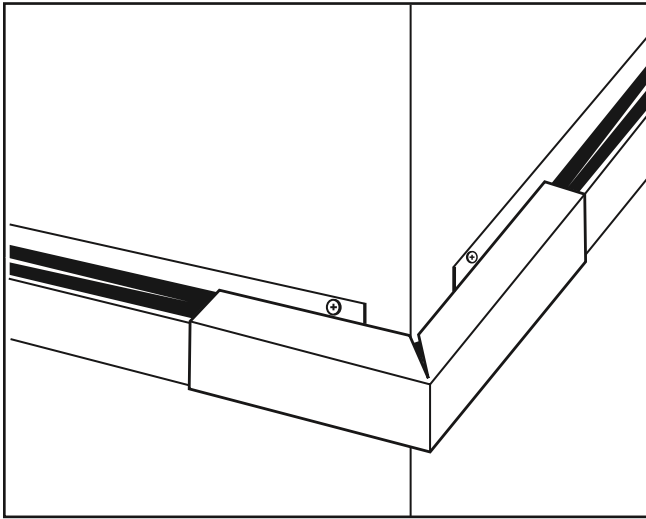

Illustration 6a

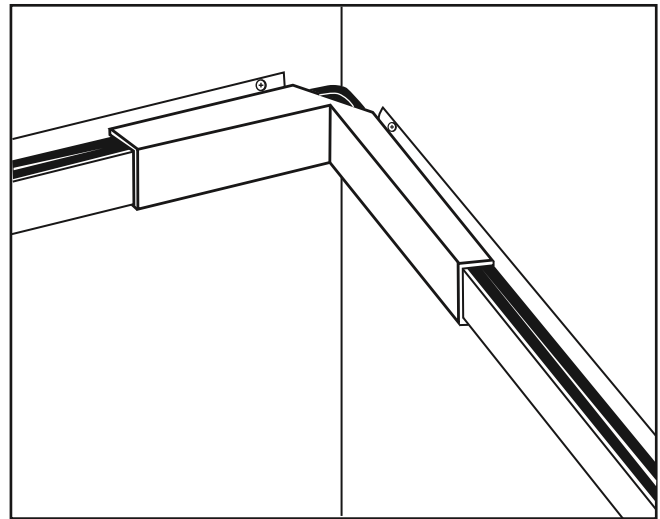

Illustration 6b

8. Fitting the Wands

First fit the lamp into its socket. Check that the lever is in the open (lever down) position. (See Illustration 7.) Check to make sure the power to the track is switched on. Position wand carefully on the track **pressing with your thumb to be sure the fitting is flat against the track.** (See Illustration 7.) This step is important to ensure that the wand is perfectly straight and flat against the track -- if it is not straight, the contact probes will not penetrate the blue track cable properly and current will not flow to the lamps.

Then turn the wand lever clockwise to the vertical position (as far as it will go). This step brings the contact probes down into the blue track cable to connect with the power lines and deliver power to the lamp. (See Illustration 8.)

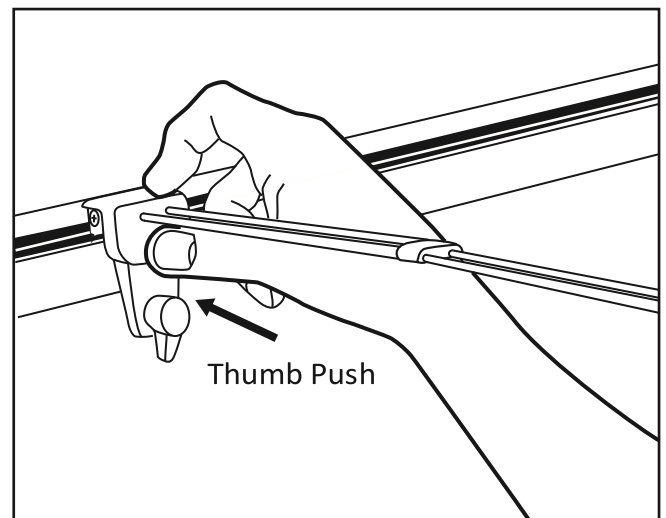

Illustration 7

You can adjust the lighting angle by sliding the lamp socket up or down. (See Illustration 9.)

9. Number of Wands

To prevent overloading the system, you should have no more than 12 wands with LED bulbs mounted on EACH side of the **Junction Box** (a maximum total of 24 wands). Greater numbers will cause the circuit breaker on the overloaded side to switch off. If this happens, remove the extra wand(s) and push the circuit breaker button on that side to switch the system back on.

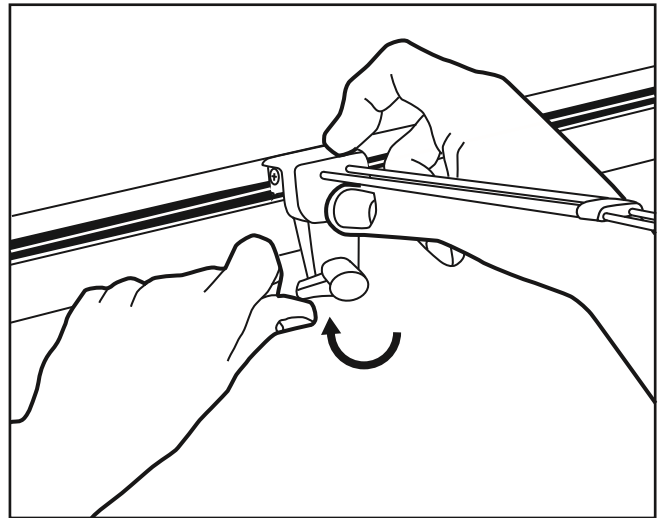

Illustration 8

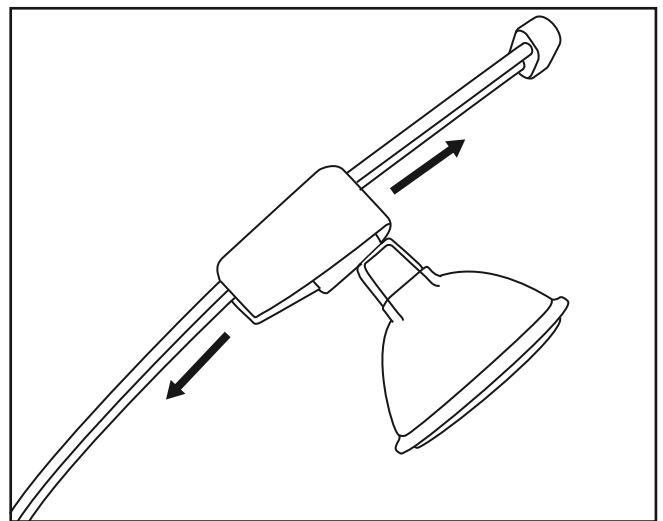

Illustration 9